

ME072

B

A

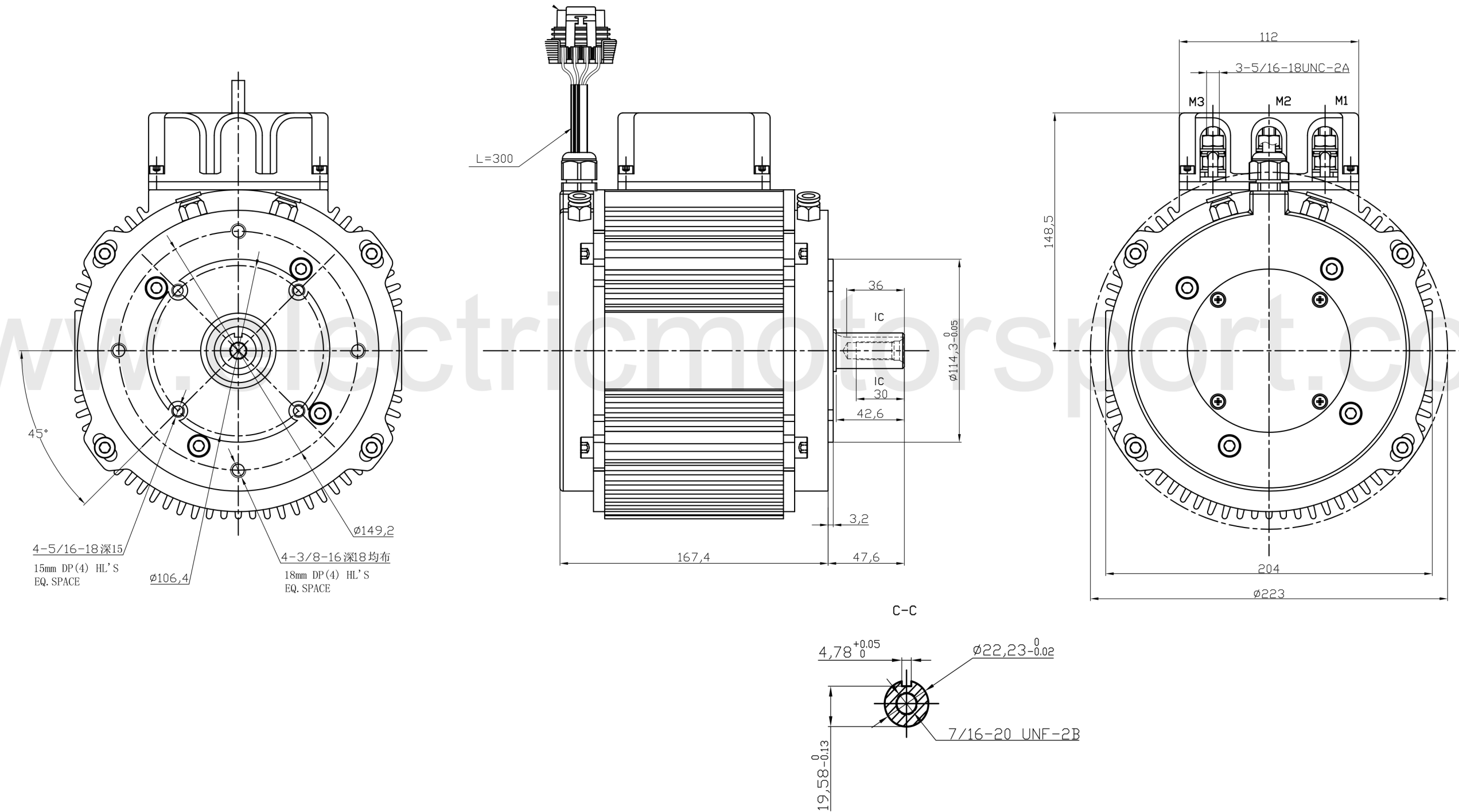

REV.	CHANGES	BY	ECO NO.	DATE	DO NOT SCALE DRAWING THIS DRAWING IS PROPRIETARY PROPERTY OF MOTENERGY INC CORPORATION DISCLOSED IN CONFIDENCE, WHICH MAY NOT BE USED OR DISCLOSED WITHOUT PERMISSION. RETURN PROMPTLY AFTER USE.	DIMENSIONING AND TOLERANCING PER ANSI Y14.5M-1994	MATERIAL	TITLE	Electric Motorsport, Inc.
-	-	-	-	-	-	-	-	OUTLINE	-
-	-	-	-	-	-	-	-	DRAWN: lxp 12.09.10	-
-	-	-	-	-	-	-	-	APPR:	DESIGN VENDOR: -
-	-	-	-	-	-	-	-	DEPT:	OJW. 302. 078
-	-	-	-	-	-	-	-	SCALE: -	REV SHEET 1 OF 1

4

3

2

1

5

A

B